

Westire Zhaga Socket, Dust Cover & Bracket Kit

ACCESSORIES

Ideal for photocell & IoT
upgradability of outdoor LED
lighting luminaires either
mounted on top of the luminaire
canopy or on the Westire Wall &
Pole Mounting Bracket



Features & Benefits

- IP66 sealing when cover or photocell fitted.
- No mounting screws necessary.
- Simple insert and "rotate & lock" feature when inserting Zhaga photocell.
- High impact protection rating.
- Tested & certified.
- Scalable solution with the receptacle accepting modules built on the 40mm or 80mm photocell.
- Base assembly.
- Poke in wire insertion for ease of socket wiring.
- Sealing gaskets included.

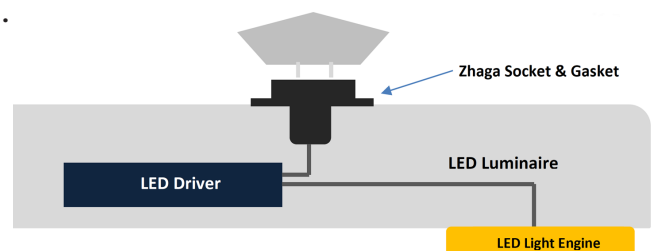

Power	
Contact Rating	5A / 250V
Dielectric Withstand	15V
Conforms to	ANSI C136.10 - 2017 UL UV (fl) & CB
Operating temperature	-40° C to +80° C -40° F to +176° F

Socket Wiring	
Red Wire	24V - 40V DC (Photocell)
Grey Wire	DALI -
Voilet	DALI +
AUX	Not used

Wiring

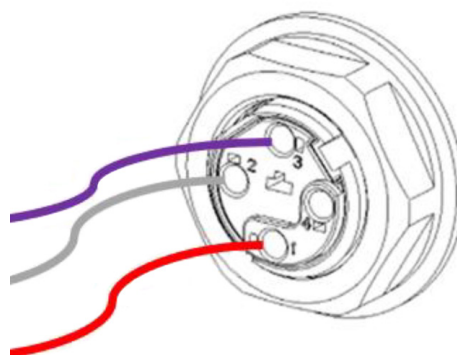
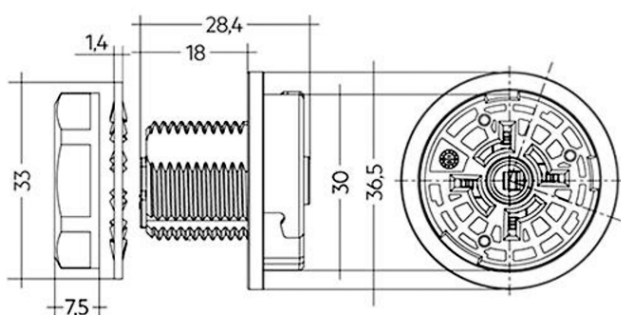

Dimensions

