

## Westire DC Power Tap

### Power Tap

The market's most versatile method of providing DC power to Wi-Fi or IoT devices through a streetlight luminaire's ANSI/NEMA receptacle, delivering auxiliary power to third-party equipment.



The Westire DC Power Tap provides auxiliary power directly from the ANSI/NEMA socket to third-party equipment such as WiFi or other smart IoT devices, while maintaining the normal operation of the photocell.

It is designed to easily insert into a three-or-seven pin ANSI/NEMA twist-lock socket, either mounted on the canopy of a streetlight or a wall-or-pole-mounting bracket.

### Simple to install:

1. **Remove the photocell from the ANSI/NEMA socket and insert the Power Tap.**
2. **Insert the removed photocell back into the power tap's own ANSI/NEMA socket.**
3. **Connect the Power Tap's cable to your third-party auxiliary device requiring the supply**

### Features & Benefits

- **Direct Powering** – 12 V, 24 V, & 48 V DC Smart IoT devices directly from your streetlights ANSI/NEMA socket.
- **Powering** - Festive or amenity DC outdoor lighting from streetlights.
- **External easy to access fusing** – Protecting the connected DC devices.
- **Cable Length** - Supplied with a 2-metre cable as standard; other customisable lengths available on request.
- **Enclosure Protection** – Water and dust tight rating of IP65.
- **Optional Mounting** – Westire wall or pole mounting bracket available.

General		Environmental	
Dimensions	113 mm (H) x 83 mm (W) 4.45" x 3.27"	Operating Temperature	-20° C to +80° C -4° F to +176° F
Warranty	5 Years	Power Tap Enclosure	UV stabilised polycarbonate
Cable Length	2 meters standard (other lengths available on request)	Material & Sealing	Polycarbonate housing sealed to IP65
Power		Standards	
Mains Supply	85 V - 264 V AC 50/60 Hz	Power Tap receptacle	Designed to BS5972 & ANSI C136.41
DC Output Voltage	5 V DC	Connecting pins	Designed to BS5972 & ANSI C136.10
DC Output Current	5 A		
Other Output Voltages & Currents	Available on request		

## Westire Power Tap Kit

**Westire DC Power Tap**



**Westire ANSI/NEMA Socket & Bracket**



**ANSI/NEMA Wall or Pole Mounting Bracket Dimensions**

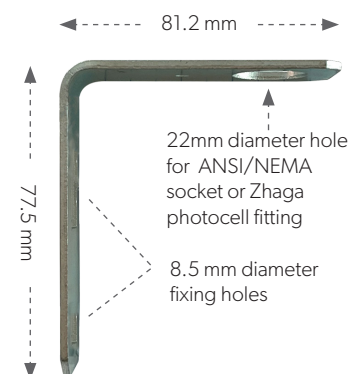

Manufactured in-house using only high-quality name brand components, Westire products are renowned in the industry for their unparalleled quality and reliability